

White Paper

AC Surge Protection

Evaluation of Series Element Surge Protective Device for Protection of Electronic Equipment and Systems

Richard Odenberg, Research & Advanced Applications,

an INFINIT[®] company

Table of Contents

Introduction	3
Application & Characteristics	4
Impedance of the AC Power vs. Telephone Lines	4
Functional Description	4
Failure Modes	5
Poor Voltage/Surge Current Coordination of S_1 and S_2	5
S_2 Failure by Repetitive Transients	5
Load Regulation	5
Resonant Circuit	5
Load Fault Safety Considerations	5
Adding Capacitors to Filter Noise	5
Series inductor Design Parameter	6
Reliability and Life Expectancy of the Major Protection Components	6
Summary	6
Conclusion	7
Figures	
Figure 1: Series Hybrid Suppressor Circuit	3
Graph 1: Impedance vs. Transient Surge Duration	7

Evaluation of the Series Element (Two-Port) Surge Protective Device on the AC Power Lines for Protection of Electronic Equipment and Systems

Introduction

This report evaluates the design, protection capability and failure modes of the AC Series Element Two Port Surge Protective Devices currently used in the industry.

In the 1980's a number of surge protective device manufacturers found that to effectively protect the technology of solid-state circuitry from surge voltages, they had to make a change. Gas tubes did not adequately protect because of their slow response and high-voltage turn-on. MOV (Metal Oxide Varistor) suppressors were not a strong option either because of their degradation characteristics. The combination of MOV and gas tubes in a circuit, however, appeared to be an option to replace single device technologies. This combination circuit (Figure 1) was comprised of a suppressor S_1 on the AC input and a series impedance (resistance or inductance) followed by a suppressor S_2 on the load side. Termed a Series Element Surge Protective Device (SESPD), the circuit is also known as a hybrid and as a two-port surge protective device.

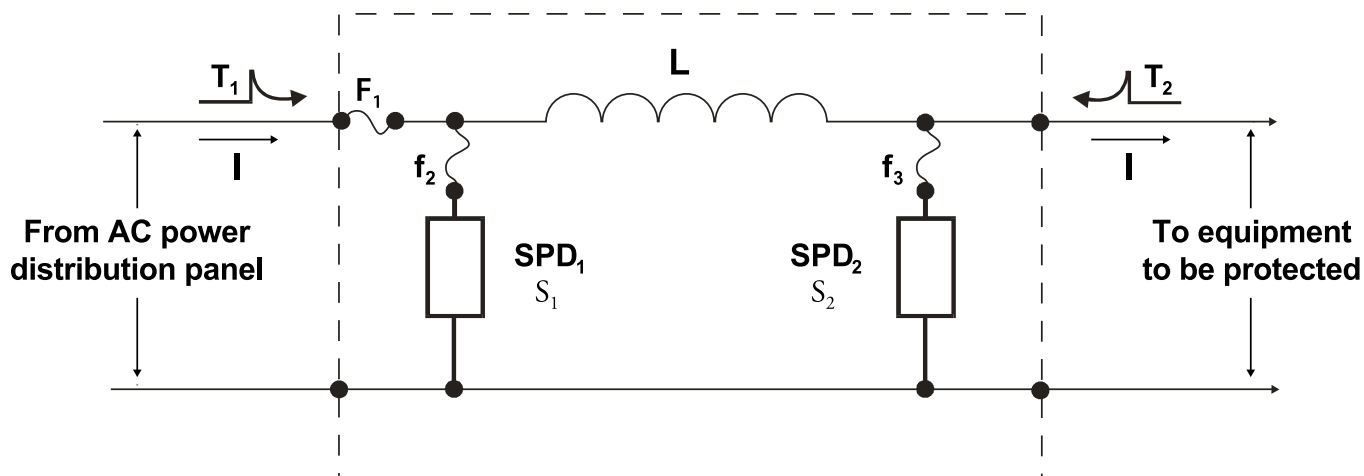

Figure 1 shows a two-port surge protective device, or hybrid, using two different surge protective technologies (i.e. GAP or gas tube and MOV).

Application and Characteristics

Impedance of AC Power vs. Telephone Lines

The history of the hybrid circuit goes back to the early 1970's when its initial application was protecting telephone lines.

These origins are important to remember when evaluating hybrid circuits because the characteristic impedance between AC power systems and telephone signal lines differs considerably. While the impedance of lines in telephone systems are fixed at a higher level of 600 to 1,000 ohms, the impedance of most AC power systems is very low (a few ohms.)

Damaging surges on the telephone lines are almost always caused by lightning, producing high-voltage, high-surge currents and very short pulse duration. (i.e. 50 μ sec)

Surges on AC power lines are quite different. In addition to lightning, they are also exposed to utility power switching surges, other user switching and internal facility switching surges. The characteristics of these surges can be high-voltage and high-surge current, but unlike lightning, with very long pulse duration. (i.e., 500 to 1000 μ sec)

A hybrid surge protective device (SPD) used in AC power applications must protect itself not only from surges generated from the AC line side, but from the load side as well; e.g., fuse clearing – due to faults, computers or air conditioning systems switching on and off. A surge generated from the load side can be almost as large as one generated from the line side. The telephone line circuit does not have this condition because of the method of application.

In AC power systems, surge conditions can occur daily, hourly, or every minute. Lightning, on the other hand, is seasonal and does not happen very often compared to the AC power system occurrences. Therefore, with a hybrid SPD, the operating life in the telephone application can be long, but on the AC power systems failure, can occur frequently.

Functional Description (Figure 1):

The S_1 has generally a much higher energy capability than S_2 . Typically S_1 can be either a gas tube or an MOV. The S_1 (a gap type) suppressor with its slower response, high current and voltage limiting level, higher than S_2 , conducts; thereby taking the majority of the surge. To allow this to occur a series impedance is installed to separate the S_1 and S_2 suppressors. This impedance can be a resistor, inductor, or a series combination of the two (depending upon the application) due to the slow response of S_1 . The inductance (L) slows the surge down (stretches it out) to allow for S_1 to start to conduct before S_2 . This inductive impedance must be sized to pass the operating AC power on the line being protected. It should not be too large of a value to cause high power dissipation or regulation problems. Meanwhile, S_2 , the lower voltage limiting and power level suppressor (MOV or SAD) limits the remnant that was left over by the slow response of the S_1 suppressor, typically a gas tube or even an MOV.

The suppressors S_1 and S_2 are generally not the same technology; e.g., gas tube, MOV or silicon avalanche diodes (SAD). Coordinating operating times and the surge current ratings between S_1 and S_2 are critical to a successful design.

Failure Modes

The following are application examples of possible failure modes of the AC Series Element Two-Port SPD and/or equipment malfunction:

1. Poor Voltage/Surge Current Coordination of S_1 and S_2

If the S_1 suppressor fails to turn on, the surge will pass through to destroy the S_2 suppressor. Also, if the S_1 suppressor does not turn on fast enough, or at a low enough voltage, the surge will destroy the S_2 suppressor. In addition, history has shown many failures of the hybrid SPD result from surges generated from the load (T_2) rather than the line (T_1). S_2 on the load side is the device that fails – whereas S_1 is not affected.

2. S_2 Failure by Repetitive Transients

A very common failure of S_2 and the computer occurs when the computer power supply is using a switch mode design. The failure source is a surge caused by the switching characteristics of the power supply in combination with the suppressor system's lead lengths, parasitic inductance and capacitance. A single load side surge occurrence can cause complete failure, but at a minimum repetitive load side surges will cause degradation of S_2 . In main and branch electrical panel applications the surge current rating of the suppressor S_2 needed on the load side is almost as large as that of the suppressor S_1 used on the line side. With the series inductor (L) isolating the load from the line, the small load side suppressor S_2 must absorb all of the surge energy generated by the distribution system.

3. Load Regulation

Malfunction of the computer system can be caused by poor load regulation due to the series inductor (L) and lead lengths between the suppressor and the computer limiting the current draw. This can cause the DC output voltage of the computer's switching power supply to change. The end result is that the user sees the computer function properly sometimes, and at other times the computer produces errors. In general, there is no hard equipment failure but the computer is not always 100 percent operational and error free.

4. Resonant Circuit

The inductive, capacitive, and resistive components in the series element SPD and computer power supply switching circuit may oscillate or resonate with each other causing sine wave distortion. In addition, switching power supplies can cause harmonic distortion, which enhances the resonant oscillatory problem. This tuned hybrid circuit may cause a computer to function erratically due to the switch mode power supply turning on and off at different times. In addition, the hybrid circuit could resonate with one computer and not with another due to a built in filter within the AC/DC power supply.

5. Load Fault Safety Considerations

If the load should fail shorted, the series inductor in the hybrid suppressor must be designed to handle the short-circuit current of the AC power system until the circuit clears. A hybrid SPD should always meet the fire and safety requirement of UL 1449, which requires fault testing of the systems based on the AC power requirements that will be used.

6. Adding Capacitors to Filter Noise

Caution should be noted when the hybrid SPD has a filter to reduce electrical noise on the line. Capacitors are extremely sensitive to abnormal voltage levels and may fail dramatically providing further reason for requiring UL compliance for fire and safety.

7. Series Inductor Design Parameters

When a series inductor (L) is used to coordinate of S_1 and S_2 , it will make this design very difficult, due to the complex and varying voltage rise times and durations of the “real world” surges. The best calculations can go astray since the entire situation is highly nonlinear. Most hybrid circuits are designed and tested to laboratory waveforms (8/20) rather than the waveforms of the everyday electrical environment.

8. Reliability and Life Expectancy of the Major Protection Components

In a design where S_1 is an air gap or gas tube and S_2 is an MOV or SAD, the following conditions should be considered:

(S_1 = GAP (Gas Tube, Air Gap); S_2 = MOV or SAD)

- A. It is widely known that after the first suppression of the surge voltage by a gas tube S_1 , the gas tube begins to degrade. In addition, the gas tube or air gap shorting the AC power line causes distortion in the sine wave. A resistor in series with the GAP S_1 and MOV S_2 is commonly used to help prevent this problem. Unfortunately, the resistor reduces the effectiveness of the device’s capability to divert the surge and can produce additional problems. For example, if using a wire wound resistor, the response time is reduced due to inductive characteristics and the voltage limiting level is increased. This means the S_2 has to handle more energy.
- B. With an inductor in series, inductive surges may be produced when a fuse upstream in the system opens, causing computer equipment to operate erratically or fail.
- C. Whether used on S_1 or S_2 , MOVs degrade by either thermal runaway or repetitive surges.
- D. Silicon Avalanche Diode have long term repeatable performance with no degradation. They have a positive temperature coefficient, so thermal runaway is not a problem. However, if power dissipation is exceeded, because not enough SADs are incorporated, the device will fail.

Summary

Major issues when considering using a series hybrid SPD include:

1. Series inductor design parameters in real life vs. laboratory waveform testing (see Graph 1) – The inductors X_L (impedance) will vary with the (T_1) surge duration. Therefore, it can be difficult to coordinate S_1 and S_2 suppression elements because real life waveform durations vary considerably.

Graph 1 Impedance vs. Transient Surge

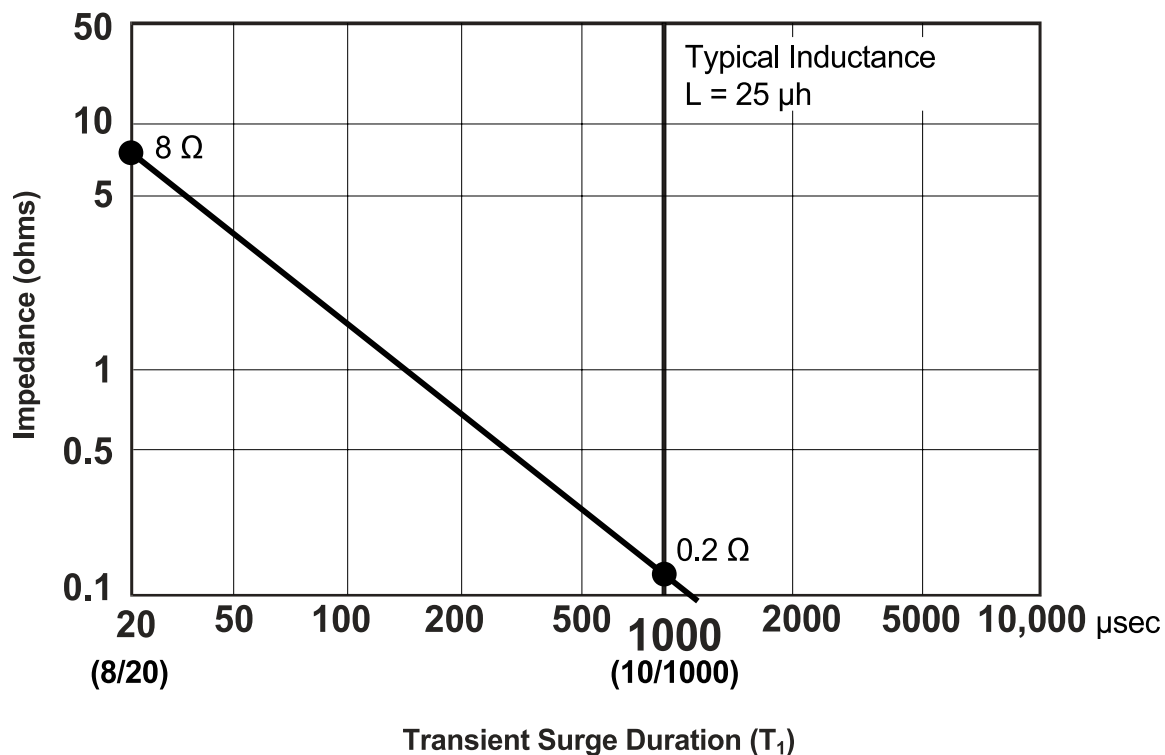

2. Limited life – GAP and MOV surge components degrade with use.
3. Harmonic and load regulation problems – Waveform distortion can lead to these disturbances.
4. Resonances by inductor, capacitor – Variable lead lengths of circuits with components in switching power supplies can cause this issue.
5. Power dissipation (S_1 vs. S_2) – Bi-directional surges and load generated surges can wear out or destroy S_2 .
6. Load fault safety conditions (UL 1449) – The ability of the series hybrid suppressor inductor or suppressor element to handle short circuit current during the shorting of a load or suppression element, as well as the residual energy from the inductor following the opening of an AC fuse upstream are vital fire and safety considerations.

Conclusion

As enumerated, the series hybrid (two-port) surge protective device may not provide adequate, safe surge protection for today's sensitive computer systems. Instead, it is recommended to use a parallel SPD utilizing surge components that are not waveform duration dependant. They must also handle high surge current without degrading.

Please contact us for questions or further information on this topic.

Contact:

Tel: (+1) 208-772-8515

Email: sales@transtector.com

www.transtector.com